

ZET-Horn 90/110 AC

The ZÖLLNER ZET-Horn was the first piston type whistle on the world market driven by an AC 3phase motor. An essential component is the piston inside the cylinder driven by an AC 3phase motor via connecting rod, crankshaft and gearwheels. The piston oscillates at a certain frequency which makes the air inside the sound projector vibrate in resonance to produce a sound audible over a wide range.

Essential information:

- » full compliance with the COLREGS 1972, Annex III
- » type approved by all wellknown international authorities and classification societies
- » system voltage: AC 3phase/control box AC 1phase
- » entirely made of best non-corrosion, seawater resistant materials: gearwheels made of wear-resistant upgraded steel

Application:

- » vessels of class I (200 m or more in length)
- » land alarm, i.e. bunker stations, oil refineries, airports, power plants, factories

Options:

- » rubber metals for vibration reduction
- » special design for arctic class available

Advantages:

- » decades of experience
- » best material and workmanship - made in Germany
- » entirely made of best non-corrosion, seawater resistant materials
- » simple but matured design: easy exchange of all parts with onboard tools, steady lubrication with standard grease (no oil!)
- » cylinder suspended vertically to allow optimum discharge of spray, flood, condensation water or melted snow
- » motor heating to avoid condensed water included as a standard - no additional cable required!

Sound Characteristics

- » broad frequency spectrum with many higher harmonics
- » signals with strong overtones for best penetration of background noise level: Even when a background noise covers the actual basic frequency the residual tone forms a parent frequency in the human hearing. Two or three harmonics are sufficient for the hearing to perceive the basic frequency.
- » sound frequency of 90 Hz / 110 Hz very advantageously ranks in the lower admissible range (70-200 Hz)
- » sound pressure level 143 dB in 1/3rd octave band at 1 m distance

Easy Installation:

- » only one three-core cable required for connection to board mains
- » relatively low weight
- » not affected by voltage and frequency fluctuations of board mains



Technical information

Positioning and installation

Positioning as high as practicable on the vessel to reduce interception of the emitted sound by obstructions and to avoid hearing damage risk to the personnel. The sound pressure level of a vessel's own signal at listening posts must not exceed 110 dB(A).

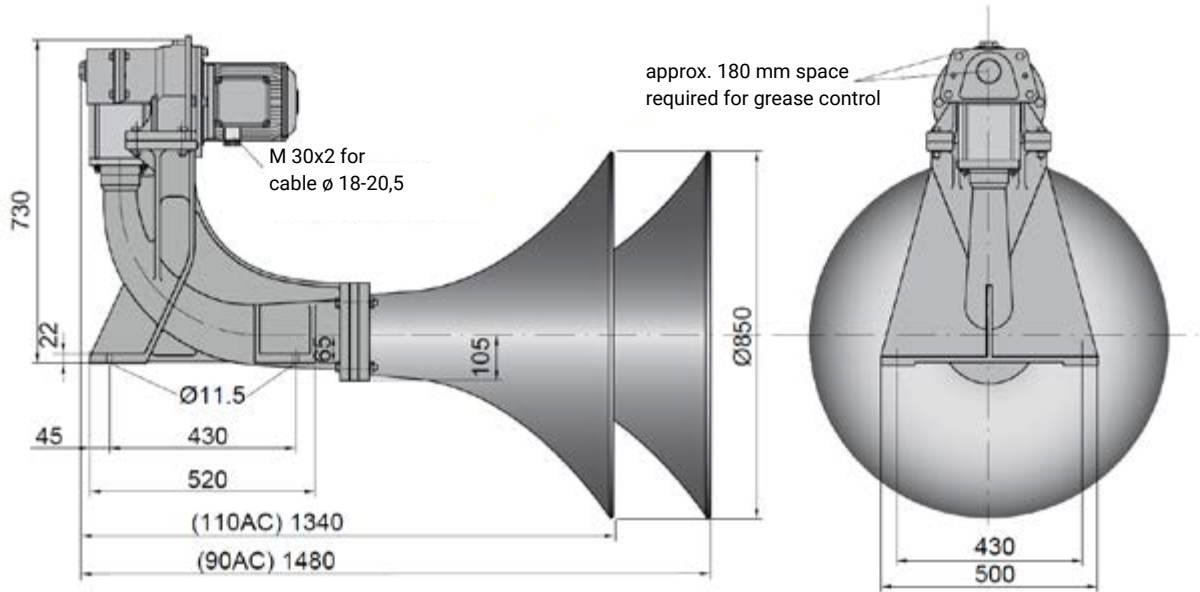

90AC weight approx. 90 kg
110AC weight approx. 92 kg

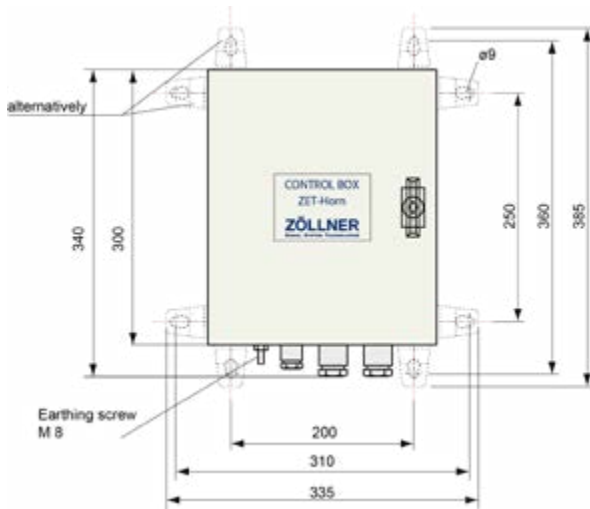

drawing 01415158

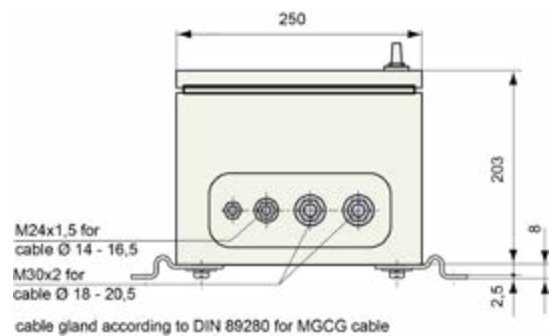

Standard control box
(supply voltage 380 / 440 V - control voltage 115 / 220 V)
- other voltages on request

weight approx. 8,7 kg

TYPE	SHIP LENGTH	FUNDAMENTAL FREQUENCY	SOUND INTENSITY IN 1/3RD-OCT. BAND LEVEL AT 1 M (MIN. 143 DB ACC. TO IMO)	TYPE APPROVAL	MOTOR OUTPUT	MOTOR HEATING	PROTECTION TYPE
90AC	> =200 m	90 Hz	143 dB	✓	5,5 kW	100 W	IP 56
110AC	> =200 m	110 Hz	143 dB	✓	5,5 kW	100 W	IP 56